

Voertuigen

Portfolio



AS **AUTOMATIC**
SYSTEMS

Access controlled...
Future secured



Tolwegen

TollPlus 160

- Openingsnelheid: 1,2 sec. min.
- Vrije doorgang max.: 4 m
- Ovale aluminium arm met uitrijkleem

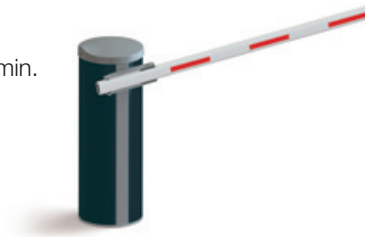

TollPlus 262

- Openingsnelheid: 0,6 sec. min.
- Vrije doorgang max.: 4 m
- Ovale aluminium arm met uitrijkleem



TollPlus 260

- Openingsnelheid: 0,7 sec. min.
- Vrije doorgang max.: 4 m
- Ovale aluminium arm met uitrijkleem



BL 229 Toll

- Openingsnelheid: 0,6 sec. min.
- Vrije doorgang max.: 3 m
- Ovale aluminium arm met uitrijkleem
- Mechanische vergrendeling



Parkingslagbomen

ParkPlus 100 / 101

- Openingsnelheid: 1,2 sec. min.
- Vrije doorgang max.: 4 m
- Ovale aluminium arm/knikarm



BL 229

- Openingsnelheid: 1 sec. min.
- Vrije doorgang max.: 6 m
- Ronde-, platte- of knikarm in aluminium
- Mechanische vergrendeling



ParkPlus 244

- Openingsnelheid: 1.2 sec. min
- Vrije doorgang max.: 4 m
- Semiversterkte aluminium arm (Knikarm is optioneel beschikbaar)

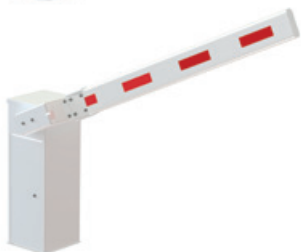

BL 44

- Openingsnelheid: 2 sec. min.
- Vrije doorgang max.: 4 m
- Versterkte aluminium arm
- Anti-vandalisme slagboom
- Mechanische vergrendeling



VOORBEELDEN

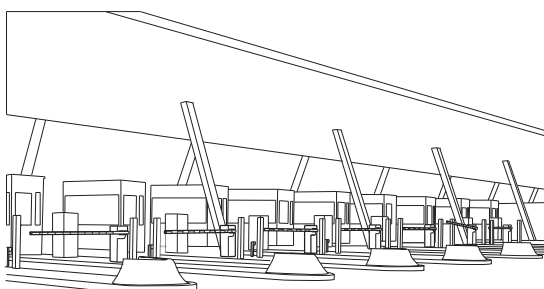

Autosnelweg

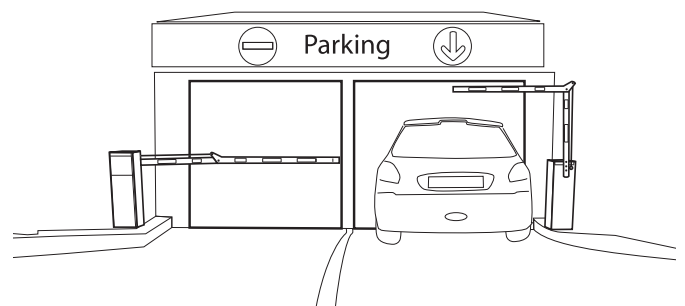

Parking

Verkeersmanagement

BP 56

- Openingsnelheid: 9 sec.
- Vrije doorgang max: 8 m
- Versterkte aluminium arm
- Horizontale opening en sluiting van de arm

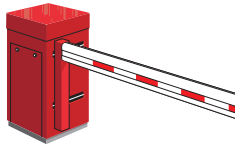

BL 45A / 45F / 45T

- Openingsnelheid: 3,5 - 8 sec.
- Vrije doorgang max.: 12 m / 10 m
- Aluminium- of glasvezel arm



BL 52

- Openingsnelheid: 8 - 12 sec.
- Vrije doorgang max.: 14 m
- Ronde aluminium arm

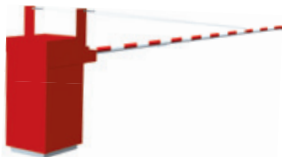

BL 77

- Openingsnelheid: 10 - 24 sec.
- Vrije doorgang max.: 14 m
- Aluminium- of glasvezel arm



Slagbomen met hekwerk

BL 46

- Openingsnelheid: 3,5 sec. min.
- Vrije doorgang max.: 7 m
- Meescharnierend aluminium hekwerk



BL 47

- Openingsnelheid: 5 sec. min.
- Vrije doorgang max.: 4,35 m
- Hoogte van het hekwerk: 2 m
- Vast aluminium hekwerk

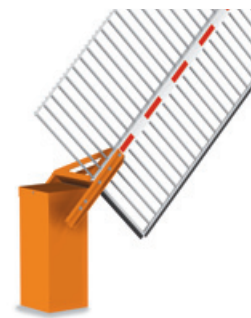

BLG 76

- Openingsnelheid: 8 - 12 sec.
- Vrije doorgang max.: 5 m
- Hoogte vanaf de grond max.: 2,3 m
- Gevlochten hekwerk



BLG 77

- Openingsnelheid: 7 - 10 sec.
- Vrije doorgang max.: 6,15 m
- Hoogte vanaf de grond max.: 3,46 m
- Gevlochten hekwerk



VOORBEELDEN

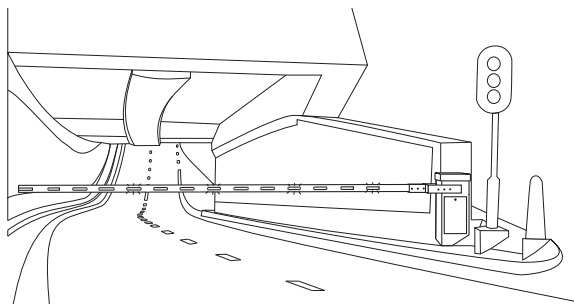

Verkeersmanagement

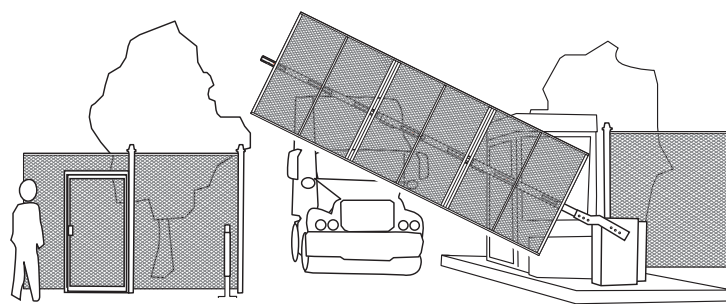

Afgesloten sites

Perimeterbeveiliging

BL 10

- Manuele slagboom
- Vrije doorgang max.: 8 m



BL 15

- Openingsnelheid: 1,2 sec. min.
- Vrije doorgang max.: 4 m
- Ovale aluminium arm



BL 227

- Openingsnelheid: 1.5 sec. min.
- Vrije doorgang max.: 6 m
- Ronde aluminium arm



BL 229

- Openingsnelheid: 1 sec. min.
- Vrije doorgang max.: 6 m
- Ronde aluminium arm
- Mechanische vergrendeling



BL 40 / 41

- Openingsnelheid: 3,5 sec. min.
- Vrije doorgang max.: 8 m / 12 m
- Ronde aluminium arm



BL 43

- Openingsnelheid: 3,5 sec. min.
- Vrije doorgang max.: 6 m
- Versterkte aluminium arm
- Anti-vandalisme slagboom



BL 52

- Openingsnelheid: 8 - 12 sec.
- Vrije doorgang max.: 14 m
- Ronde aluminium arm
- Mechanische vergrendeling

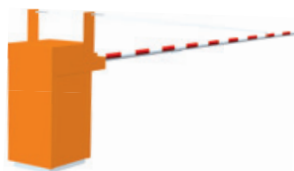

BL 53

- Openingsnelheid: 5 - 10 sec.
- Vrije doorgang max.: 8 m
- Versterkte aluminium arm
- Anti-vandalisme slagboom
- Mechanische vergrendeling



VOORBEELDEN

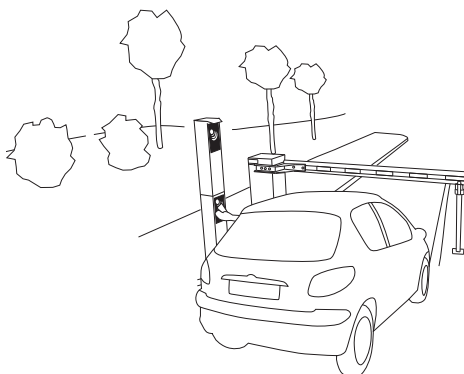

Toegangscontrole

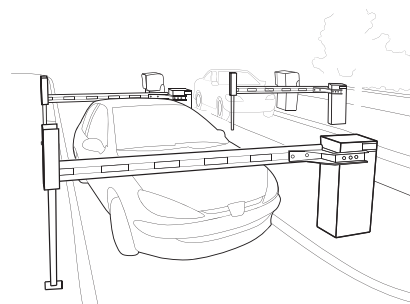

Beveiligde parkeerplaatsen

Accessoires

BOR 235 enkele / dubbele hoogte

- Mogelijkheid tot integratie van diverse accessoires
- Hoogte voor auto en/of vrachtwagen
- Ideaal voor toepassingen in combinatie met slagbomen en/of roadblockers



PST enkele / dubbele hoogte

- Mogelijkheid tot integratie van diverse accessoires
- Hoogte voor auto en/of vrachtwagen
- Ideaal voor toepassingen in combinatie met slagbomen en/of roadblockers



Zuil

- Mogelijkheid tot integratie van diverse accessoires



Hekwerk

- Verhoogd het veiligheidsniveau



Opvangpalen

- Diverse mogelijkheden leverbaar
- Verhoogd het veiligheidsniveau

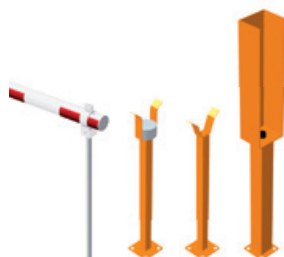

Controle & sturing

- Verhoogd het veiligheidsniveau



Personalisatie

- Integratie van klantgerelateerde producten realiseerbaar

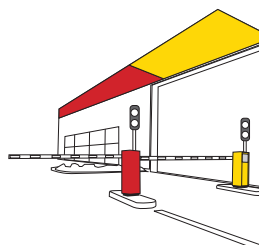

Connectiviteit

- Web server
- MODBUS/TCP
- XML/RPC

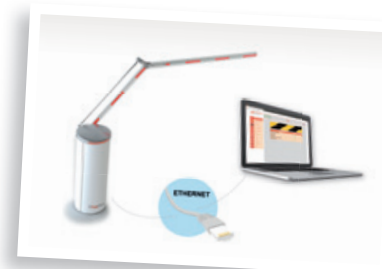

LPR/ANPR

- Integratie van LPR/ANPR-cameratechnologie



VOORBEELDEN

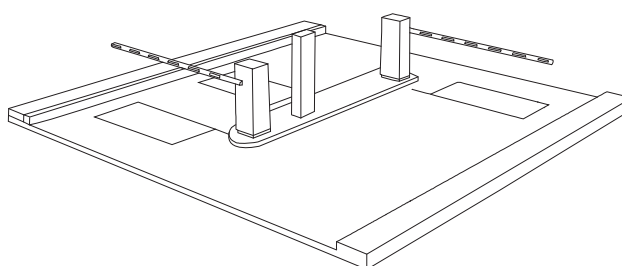

Automatische in-en uitrit

Vind de slagboom die beantwoordt aan uw behoeften	Vrije doorgang max. en/of hoogte van het obstakel	Openings-snelheid/ sluitsnelheid	Type arm							Functies				Connectiviteit			
			Standaard	Glasvezel	Semiversterkt	Versterkt	Knikarm	Koolstofvezel	Met hekwerk of rok	Automatisch openen bij stroomuitval	Mechanische vergrendeling	Uitrijkleem	Terugklapbaar	Web server	MODBUS/TCP	XML/RPC	LPR ANPR
AUTOSNELWEG																	
TollPlus 160	4 m	1.2 - 3 s	•					•*		•		•		•*	•*	•*	•*
TollPlus 260	4 m	0.7 - 2 s	•					•		•		•	•*	•			
TollPlus 262	4 m	0.6 - 2.5 s	•					•*		•		•	•*	•			•*
BL 229 Toll	3 m	0.6 - 2.5 s	•					•*		•	•	•	•*	•*	•*	•*	
PARKING																	
ParkPlus 100	4 m	1.2 - 3 s	•							•		•*		•*	•*	•*	•*
ParkPlus 101	4 m	1.2 - 3 s	•				•			•		•*		•*	•*	•*	•*
BL 229	6 m	1 - 4 s	•					•*	•*	•	•	•*		•*	•*	•*	
ParkPlus 244	4 m	1.2 - 3 s					•			•				•	•		•*
BL 44	4 m	2 - 3 s					•			•	•*			•*	•*	•*	•*
VERKEERSMANAGEMENT																	
BP 56	8 m	9 s					•					•					
BL 45A	12 m	8 s	•									•*		•*	•*	•*	
BL 45F	10 m	8 s		•								•*		•*	•*	•*	
BL 45T	12 m	8 s		•										•*	•*	•*	
BL 52	14 m	8 - 12 s	•						•*		•						
BL 77	14 m	10 - 24 s		•							•						
SLAGBOMEN MET VAST HEKWERK																	
BL 46	7 m x 1.8 m		•							•	•*	•*		•*	•*	•*	
BL 47	3.35 m x 2 m / 4.35 m x 2 m	5 - 8 s					•			•	•*	•*		•*	•*	•*	
BLG 76 H/L	4.4 m x 2.3 m / 5 m x 1.9 m	8 - 12 s	•							•		•					
BLG 77 H/M	4.88 m x 3.46 m / 4.88 m x 2.24 m	7 - 10 s					•			•		•					
BLG 77 HL/L	6.15 m x 2.85 m / 6.15 m x 2.24 m	7 - 10 s					•			•		•					
PERIMETERBEVEILIGING																	
BL 10	8 m	manueel	•														
BL 15	4 m	1.2 - 3 s	•					•*		•		•*		•*	•*	•*	•*
BL 227	6 m	1.5 - 3.5 s	•					•*		•*	•*	•*		•	•		
BL 229	6 m	1 - 4 s	•					•*		•*	•	•*		•*	•*	•*	
BL 40	8 m	3.5 - 8 s	•							•*	•*	•*		•*	•*	•*	
BL 41	12 m	3.5 - 8 s	•							•*	•*	•*		•*	•*	•*	
BL 43	6 m	3.5 - 8 s					•			•*	•*	•*		•*	•*	•*	
BL 52	14 m	8 - 12 s	•							•*		•					
BL 53	8 m	5 - 10 s					•					•					

Legenda: * Optioneel. Data niet contractueel

HOOFDKANTOOR - INTERNATIONALE VERKOOP AUTOMATIC SYSTEMS SA

Mercatorlaan 5 – 1300 Waver
BELGIË

Tel.: +32 (0)10 230 211

Fax: +32 (0)10 230 202

E-mail: sales.asgroup@automatic-systems.com

PLAATSELIJKE KANTOREN WERELDWIJD

NEDERLAND

Tel.: +31 629 199 129

E-mail: sales.nl@automatic-systems.com

FRANKRIJK

Tel.: +33 (0)1 30 28 95 50 (Voertuig – kantoor Persan)

Tel.: +33 (0)1 41 11 40 20 (Voetgangers – kantoor Suresnes)

E-mail: sales.fr@automatic-systems.com

SPANJE

Tel.: +34 (0)93 478 77 55 (kantoor Barcelona)

Tel.: +34 (0)91 659 07 66 (kantoor Madrid)

E-mail: sales.es@automatic-systems.com

VERENIGD KONINKRIJK

Tel.: +44 (0)1604 65 42 10

E-mail: sales.uk@automatic-systems.com

CANADA

Tel.: +1 450 659 07 37

E-mail: sales.ca@automatic-systems.com

VERENIGDE STATEN

Tel.: +1 516 944 94 98

E-mail: sales.us@automatic-systems.com

DUITSLAND

Tel.: +49 2303 553 4040

E-mail : sales.de@automatic-systems.com



AUTOMATIC
SYSTEMS

Access controlled...
Future secured

Onze partners vindt u
op onze website

www.automatic-systems.com