

# BL43 C50

## Technical datasheet

BL43 C50-FT-EN-01

Access controlled...  
Future secured



**M1**

Unique design for extremely high impact resistance:

- Steel IPN beam with release prevention plates.
- Beam in lowered position for impact with car bumpers (M1) reducing the penetration distance and protecting the interior or in raised position for vans (N1).
- Two supports mounted on a base with suitable reinforcements for solid anchoring and transfer of impact energy into the foundations.

Rapid operation:

- Rapid closing for optimal safety.
- Rapid opening for use as access control device.
- Instantly reversible operating mode.

Electromechanical activator for easy maintenance.

Shallow concrete foundation for easy installation.

Maximum passage width of 3 m.

Wide range of accessories for protection of the application and other uses.

*[\*] Test report available upon request.*

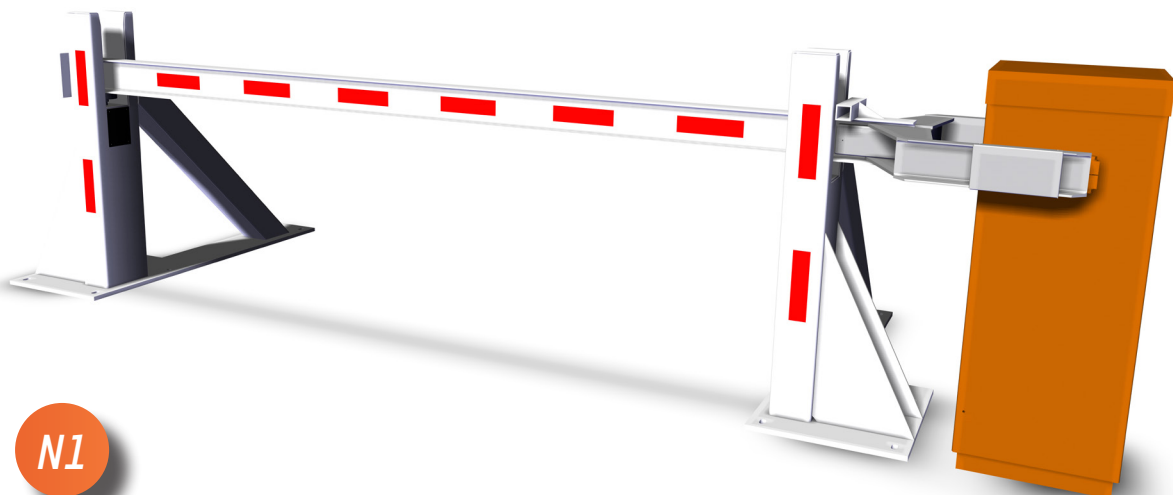

**N1**

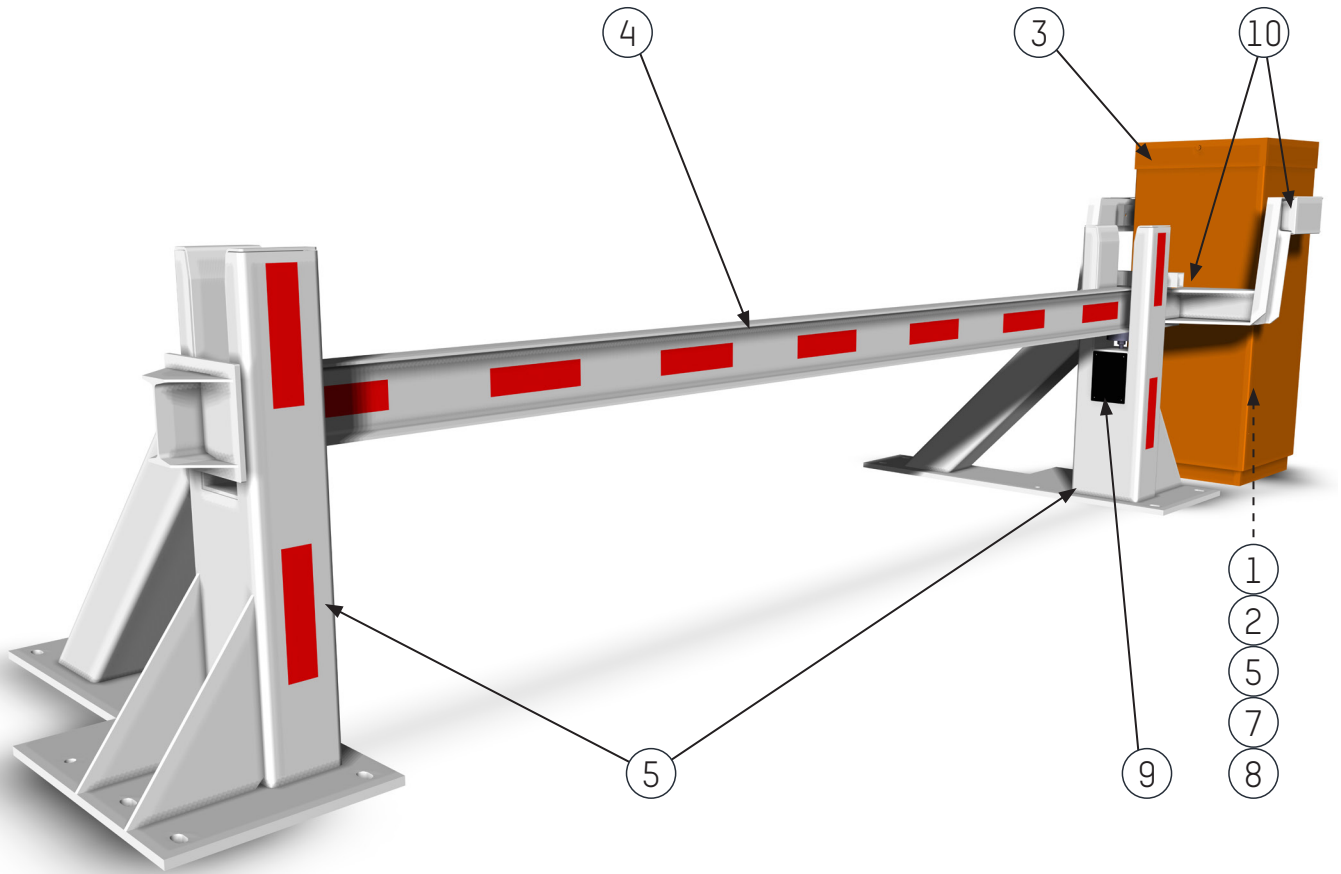

## STANDARD EQUIPMENT

1. Folded and welded sheet metal body, 3 to 8 mm thick.
2. Lateral and frontal doors with key lock, ensuring easy access to the mechanism.
3. Removable weatherproof top cover with key lock.
4. White painted central arm with red and white reflective strips. Arm built around a steel IPN beam.
5. Two supports (*struts*) with single triangulation for installing the beam. Made of white painted steel with red and white reflective strips.
6. Solid drive shaft for the arm, with 50 mm diameter, mounted on 2 lifetime lubricated bearings.
7. Electromechanical unit:
  - Reversible three-phase asynchronous gear motor.
  - Secondary transmission via gearwheel and sprocket wheel.
  - Frequency inverter ensuring progressive accelerations and controlled decelerations, for vibration-free movement and enhanced protection of the mechanism.
  - Electromagnet-controlled lock to maintain the open and closed positions during operation and in case of power failure.
  - Electronic torque limiter allowing the arm to be stopped immediately during closing in the event of an obstacle.
  - Inductive limit switches.
  - Balancing of the arm by 6 compression springs.

8. Configurable AS1320 or PLA1300 electronic control board allowing for various control options and/or additional accessories. Terminal blocks for communication with an external device to:
  - Provide status of the arm position (*open or closed*);
  - Provide status of the presence detectors;
9. Safety detection photocell (*optional*),
10. Cover for vandal-proof screws.
11. Reinforced bracket in orange colour.
12. Mechanical locking of the arm (*recommended option*)
  - In raised or lowered position during operation

## IMPACT SIMULATION

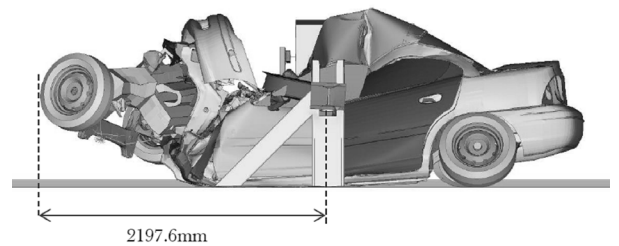

## RISING SAFETY BARRIER

Impact resistance certified by computer simulation (\*) in accordance with international standards.

Load condition specifications	
Type of vehicle as per IWA 14-1	M1
Weight of the vehicle	1500 kg
Impact speed as per standard ASTM-F2656	65 km/h
Angle of impact	90°
Energy on impact	244.5kJ

## STANDARD TECHNICAL CHARACTERISTICS

Input power supply <sup>(1)</sup>	Single phase 230 VAC, 50/60 Hz
Consumption	450 W (rated) - 950 W (max. - with the largest heating element).
Motor	Three-phase asynchronous 250 W controlled by frequency inverter.
Speed reduction gearbox	Reversible ring and pinion speed reducer, service factor 1.2
Useful length of the arm (L)	3 m
Wind resistance	120 km/h
Operating temperature:	Between -10° and +50°C.
Relative humidity	95%, without condensation
Opening speed <sup>(2)</sup>	3.5 sec
Closing speed <sup>(2)</sup>	5.5 sec
Weight of the housing	210 kg
Weight of the arm barrier (beam)	80 kg
Weight of the arm	57 kg for version M1 50 kg for version N1
Weight of the supports <sup>(2)</sup>	264 kg for version M1 380 kg for version N1
MCBF <sup>(3)</sup>	3,000,000 cycles (In compliance with recommended maintenance)
IP	44
CE	Complies with European standards

<sup>(1)</sup> Not to be connected to a floating network or to a high-impedance earthed industrial distribution network.

<sup>(2)</sup> Adjustable through the control board.

<sup>(3)</sup> Mean cycles between failures.

## SURFACE TREATMENTS

- Zinc-coated internal mechanical parts.
- Complete body (housing, base plate, cover and doors): zinc dusting + epoxy structured paint  
Total thickness of the surface treatment exceeds 160 µm.

## WORKS TO BE SUPPLIED BY THE CUSTOMER

- Adapted ground fastening.
- Power supply.
- Wiring to external peripheral equipment, if any.

*Note: please follow the installation plan.*

## SOLUTIONS

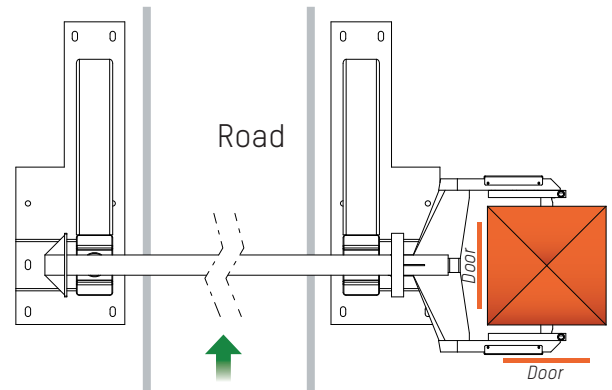

## OPTIONAL

1. Arm locking mechanism.
2. LED flashing light on cover.
3. Push-button box.
4. Fireman emergency opening.
5. Lockable switch on housing.
6. Radio transmitter/receiver.
7. Vehicle detection loop.
8. Loop presence detectors.
9. Traffic lights (Leds) - alone or on post fixed to housing.
10. Support post for traffic lights.
11. AS1049 card for third-party traffic signs.
12. LED indicator lights on arm.
13. Acoustic alarm 100 dB (±5) - mounted on the inside.
14. STOP sign panel, 300 mm diameter.
15. Photoelectric cell for opening, closing or automatic stopping of the barrier arm.
16. Treatment for aggressive saline environment.  
*(Recommended when the barrier is installed within 10 km of the coast and may be subject to salt attack): sandblasting + Alu Zinc plating 80 µm outside (40 µm inside) + polyzinc 80 µm + 80 µm powder paint)*
17. Thermostatic 250 or 500 W heating for operation to -25 or -45°C.

*Note: for restrictions regarding the options, refer to the unit type.*

# BL43 C50



Datasheet  
BL43 C50-FT-EN-01

## STANDARD DIMENSIONS (mm)

**M1**

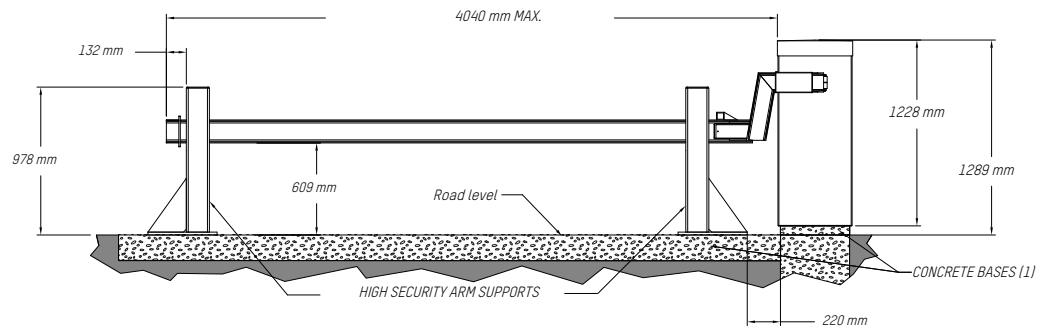
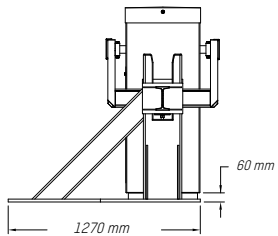
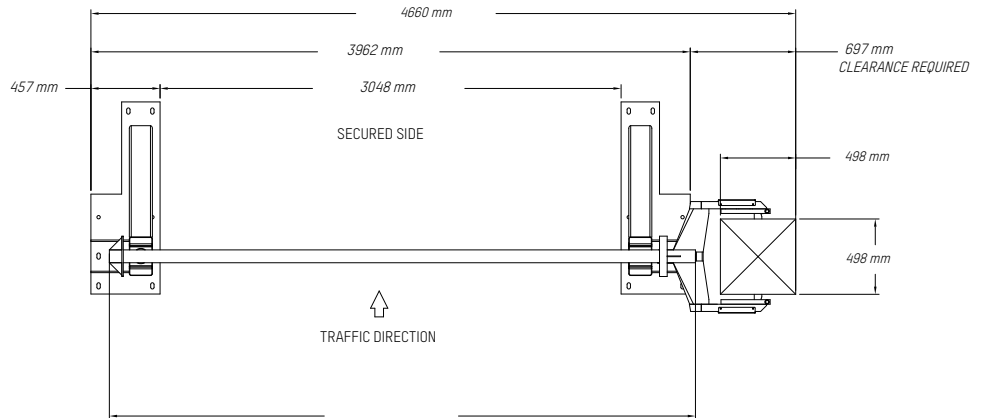

[1] FOR CONCRETE BASES REFER TO NAM-BL46-IN-01-EN & NAM-BL4X-IN-10-EN

**N1**

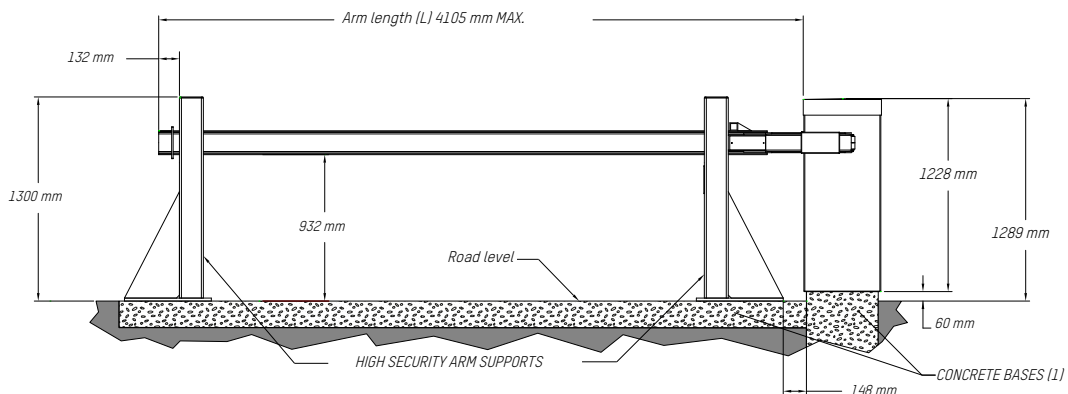
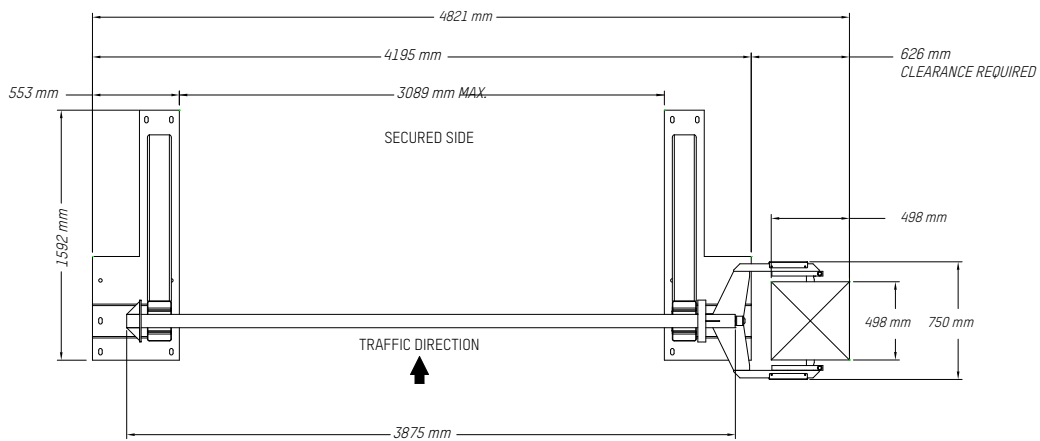

[1] FOR CONCRETE BASES, REFER TO DRAWINGS NAM-BL46-IN-01-EN & NAM-BL4X-IN-10-EN