

# FB M50\_900

## Technical datasheet

FB M50\_900-FT-EN-02

Access controlled...  
Future secured

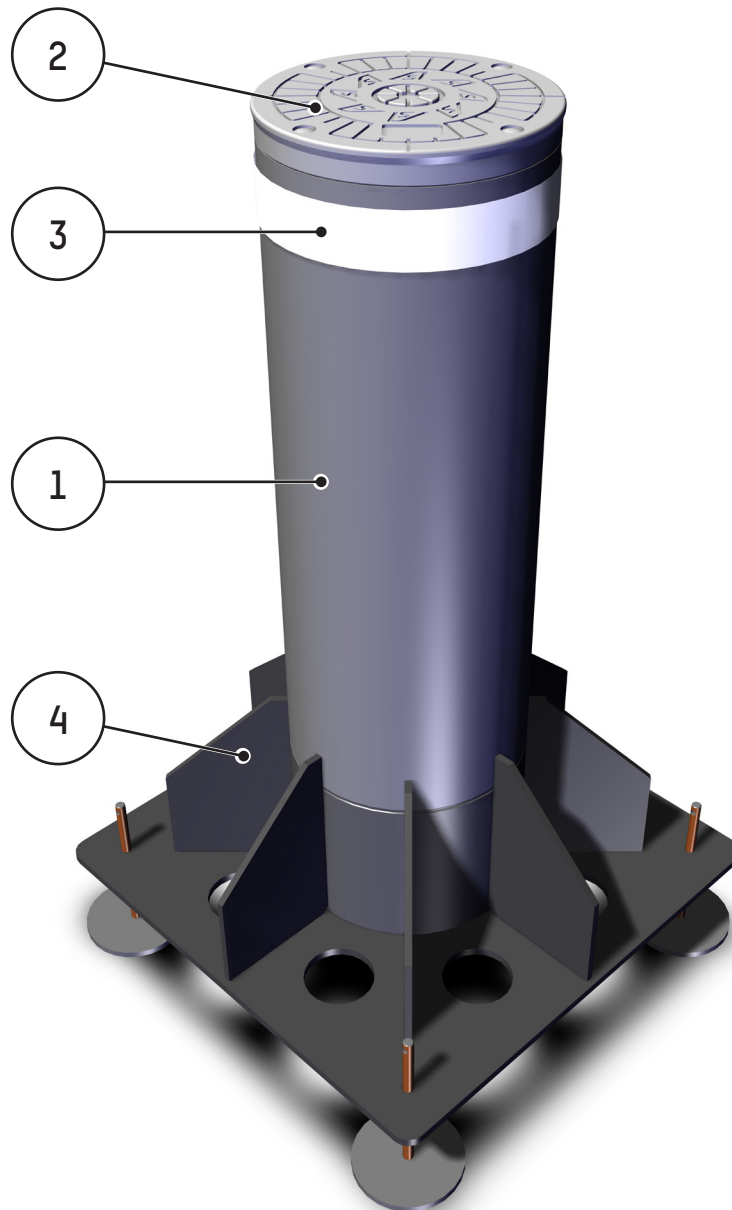

*Non contractual illustration.*

The **FB M50** high security bollard, **height 900 mm**, is designed to protect and control the access to sites that are susceptible to attempted break-in.

It can be used on any site where it is wished to create an obstacle to traffic without restricting pedestrian access.

In urban areas, it will also be perfectly adapted to the protection of shop windows and facades of buildings.

The High Security bollards have greater impact resistance than that of the other obstacles in the range (*see technical characteristics below*).

Their combination with the automatic retractable bollards RB M50\_900 will be harmonious, due to their characteristics identical to the latter (*dimensions, finishing, resistance*).

## DESCRIPTION OF THE STANDARD EQUIPMENT:

1. High security fixed obstacle consisting of a 25 mm thick painted steel cylinder.  
The obstacle is available in 3 finishes\*: painted steel, knurled painted steel or brushed stainless steel.
2. 30 mm thick cast aluminium crown.  
Crown also available with light LEDs indicators (*On the perimeter of the crown*)\*.
3. 55 mm reflective strip.
4. Obstacle supported on a thick steel section supporting structure, to seal into the concrete.

\* Product configuration to be specified when ordering.

## SURFACE PROTECTION:

### Treatment B

- Shot blasting (SA 2,5);
- Epoxy powder primer (80 µm);
- Polyester powder finishing paint (80 µm).

## STANDARD TECHNICAL CHARACTERISTICS:

### Impacts resistance certifications

Rated in compliance with:	ASTM M50 DOS K12 IWA 14-1:2013 V/7200(N3C)/80/90 PAS68:2013 V/7500(N3)/80/90
---------------------------	---

Impact resistance (Vehicles type)	3,5 T at 112 km/h 7,2 T at 80 km/h
-----------------------------------	---------------------------------------

Impact resistance	<b>1.800 000 joules.</b>
-------------------	--------------------------

Impact resistance (Without deformation)	700.000 joules.
---	-----------------

Steel cylinder Ø:	271 mm
-------------------	--------

Stainless steel cylinder Ø:	273 mm
-----------------------------	--------

Obstacle height:	900 mm.
------------------	---------

Foundation deep:	Min. 400 mm (Without leveling feet) - Max. 600 mm (With leveling feet).
------------------	--

Weight:	± 300 kg.
---------	-----------

Protection index	IP 67.
------------------	--------

Conform to European standards.

## WORKS TO BE PROVIDED BY THE CUSTOMER:

- Sealing of the frame in a concrete foundation.  
*(refer to installation drawing)*
- Drainage or connection to mains drainage.  
*(if necessary)*
- Power supply.
- Electric connections with external peripherals.

## OPTIONAL:

1. Painting with RAL colors on request of cylinder.
2. Flashing light power circuit (Max. 4).

## STANDARD DIMENSIONS (mm):

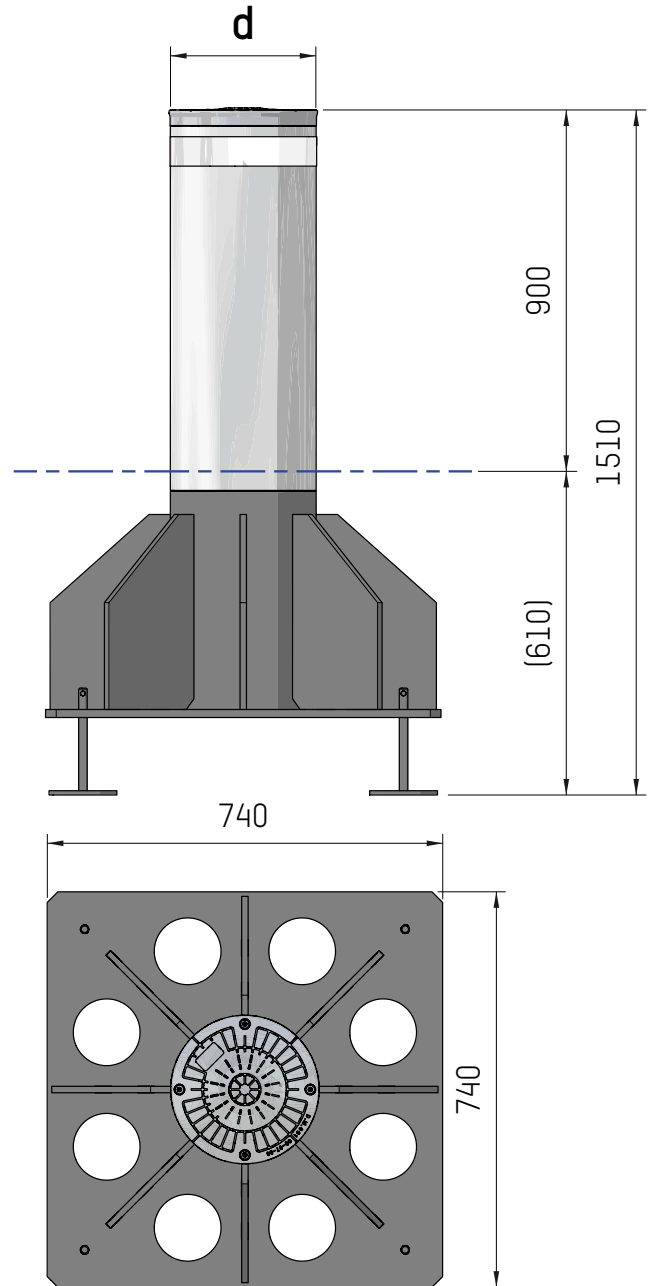

d	
Normal steel cylinder	Ø 271 mm
Stainless steel cylinder	Ø 273 mm