

RB C50

Technical datasheet

RB C50-FT-EN-02

AS **AUTOMATIC**
SYSTEMS

Access controlled...
Future secured

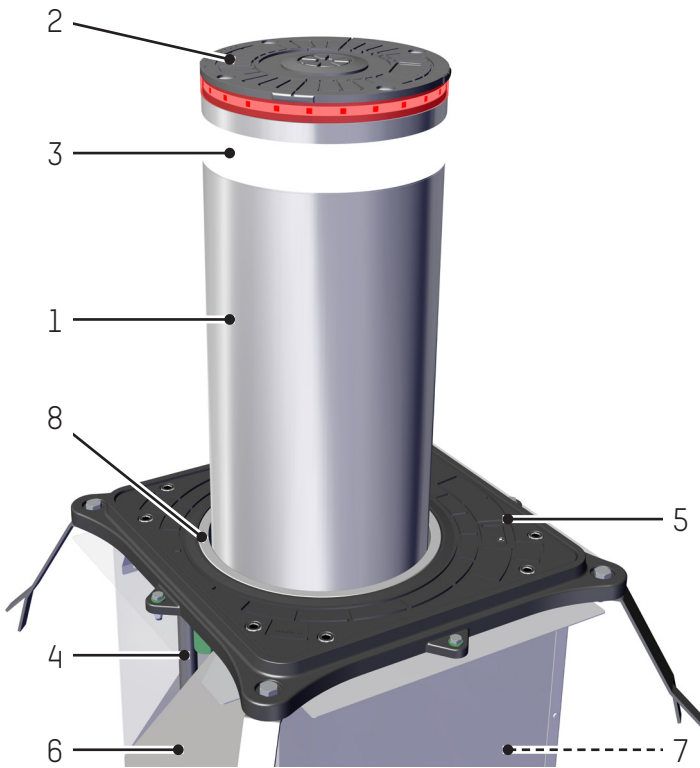

Non contractual picture.

The **RB C50** automatic rising obstacles were designed to protect and control access to sensitive sites.

This kind of equipment can be used on any site to create a retractable obstacle to control the vehicles traffic without restricting pedestrian access.

In urban environments, the RB C50 obstacles offer the advantage of being completely invisible when lowered.

They are also well-suited for controlling vehicles access to pedestrian areas.

The retractable obstacles are available with two cylinder heights from floor level, with two different code references: 600mm (**RB C50_600**) or 800mm (**RB C50_800**).

GENERAL DESCRIPTION

1. Painted (RAL 7016 - Anthracite grey) steel mobile obstacle (FE 370) diameter around 275 mm, 6 mm thick. The obstacle is available in three finishing options *: Painted steel, painted stainless steel or brushed stainless steel.
2. Anti-skid cast aluminium crown (RAL 9006 - White aluminium). The upper crown is also available with LED indicator lights (on the perimeter of the crown).*
3. Double white reflective strip on the upper part of the obstacle, 55 mm height.
4. Thick steel supporting structure.
5. Cast aluminium cover plate and link frame between the obstacle and the road surface (mounted onto the embedded casing).
6. Galvanized sheet steel embedded casing.
7. Mobile obstacle is held vertically and reinforced by means of a thick steel collar connected to the supporting structure and a built-in nylon bush and sliding along the central jack.
8. Synthetic joint.
9. Double-acting central hydraulic jack for rising and lowering the obstacle. In order to limit damage caused by moderate impacts, the obstacle is not fixed to the jack.
10. Hydraulic unit mounted on the supporting structure. Lower hydraulic pressure during rising of the obstacle to allow a reversal movement if an obstacle > 40 kg is detected. Full pressure is applied during the final 10 cm of the rising cycle and in the up position.
11. The hydraulic pump is automatically switched off in the up position by receiving a pressure switch signal.
12. Steel/rubber bearings support the obstacle in low position, allowing it to withstand the passage of heavy vehicles.
13. Inductive sensor delivers to the logic control board a low position status information.
14. A remote microprocessor control board is located in a cubicle separated from the obstacle (10 m of electric cable provided). The features include dipswitches to modify the settings, LED display for obstacle status information and inputs/outputs level.

* Product configuration to be specified when ordering.

SURFACE PROTECTION

- Treatment:
 - o Sandblasting
 - o Anti-corrosion powder painting (80 µm)
 - o Polyester powder painting (80 µm).

STANDARD TECHNICAL CHARACTERISTICS

Certification:	Rated in compliance with : PAS68:2013 V/3500(N1)/32/90 IWA 14-1:2013 V/3500(N1)/32/90 ASTM C50	
Breakout resistance	1,5 T at 64 km/h (40 miles/h)- 3,5 T at 32 km/h (20 miles/h)	
Breakout resistance:	250,000 joules.	
Impact resistance: <i>(without deformation)</i>	40,000 joules.	
Power supply:	Single phase, 230 V - 50 Hz. <i>(do not connect to a floating network or to high impedance earthed industrial distribution network)</i>	
Max. power consumption:	400 W	
	RB C50_600	RB C50_800
Obstacle height:	600 mm	800 mm
Rising speed:	4 sec.	5,5 sec
Lowering speed:	2,5 sec.	3,5 sec
Weight:	± 161 kg.	± 182 kg
Operating temperature:	-15 to +70°C.	
Frequency of use:	1500 operations per day.	
MCBF: <i>(Mean cycles between failures)</i>	2,000,000.	
Protection index:	IP 67.	
EC compliant.		

WORK TO BE PROVIDED BY THE CUSTOMER

- Embed casing to be fixed in a concrete foundation.
(Refer to installation drawing)
- Drainage or connection to main drainage *(if necessary)*.
- 230V single phase power supply.
- Connect electrical cables between the bollard and the control unit and between the control unit and the main power supply.

OPTIONAL

1. Casing in aluzinc or in stainless steel AISI 304.
2. Suspended casing kit option
3. Metal trap for closing counterframe with screws.
4. Indicator lights *(LEDs on the perimeter of the crown)* – flashing with or without warning given a few seconds prior to obstacle operation.
5. Intermittent audible signal with or without warning given prior to obstacle operation.
6. Painting with other RAL color.
7. Anti-corrosion treatment for cylinder or/and frame.
8. Biodegradable oil for the hydraulic pipes
9. Additional electrical connection line *(connecting RB to the control unit)*. Max. 80 meters.
10. IP68 sealed fast connectors for cables interconnections
11. Heating resistance for operation at low temperatures down to -40° C or in case of use in areas highly exposed to snow or prolonged freezing conditions.
12. Mobile cylinder finishing: normal steel or AISI 304 stainless steel with ribs on surface or AISI 316 brushed stainless steel.
13. Kit of anti-tampering screws of the crown - removable key.
14. E.F.O. *(circuit for emergency rising at high speed (around 1 s))*.
15. Automatic lowering cycle in case of power failure
16. UPS *(power supply in case of power failure)*.
17. Feeder/Accumulator group on control panel for emergency lowering in case of power failure.
18. Manual up/down operation in case of power failure
19. Kit UP/DOWN position auxiliary contacts *(dry contact)*.
20. Alarm kit *(1 status contact high position RB - 1 status contact RB cover plate)*.
21. Floor metallic column for control unit.
22. Retractable structure with double pit for control unit.
23. Heating device for control unit.
24. Traffic light, LED version, Red/Green (Ø 100 mm).
25. Galvanised post for traffic light.
26. Inductive detector for safety inductive loop.
27. GSM activator for remote control.
28. Weekly/Yearly timer programmer.
29. Additional cable junction box with gel.
30. Pressure gauge to show pressure in the hydraulic pump.
31. Inductive loop for vehicle detection.
32. Photo-electric cell *(T/R or Reflex)*.
33. Cell support post.
34. Radio Transmitter/Receiver.
35. Push button box.

RB C50

Datasheet

RB C50-FT-EN-02



STANDARD DIMENSIONS (mm) FOR RB C50_600

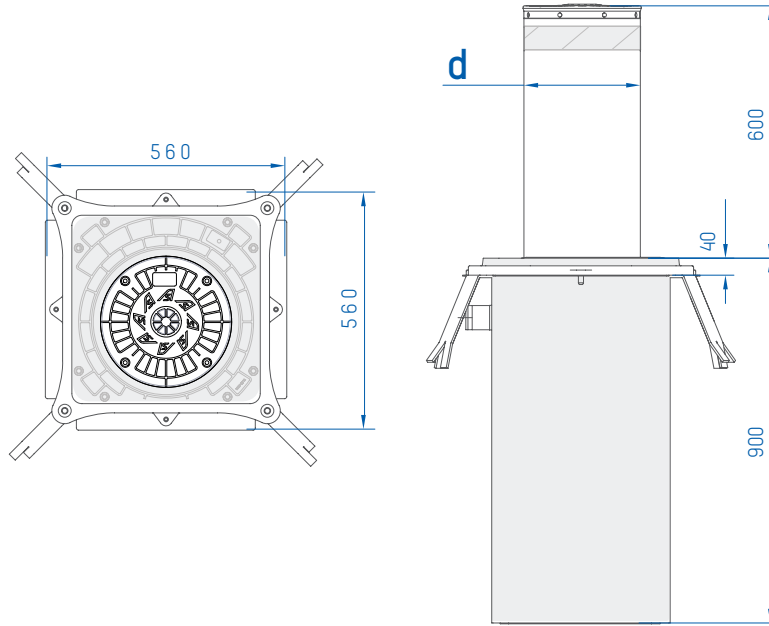

STANDARD DIMENSIONS (mm) FOR RB C50_800

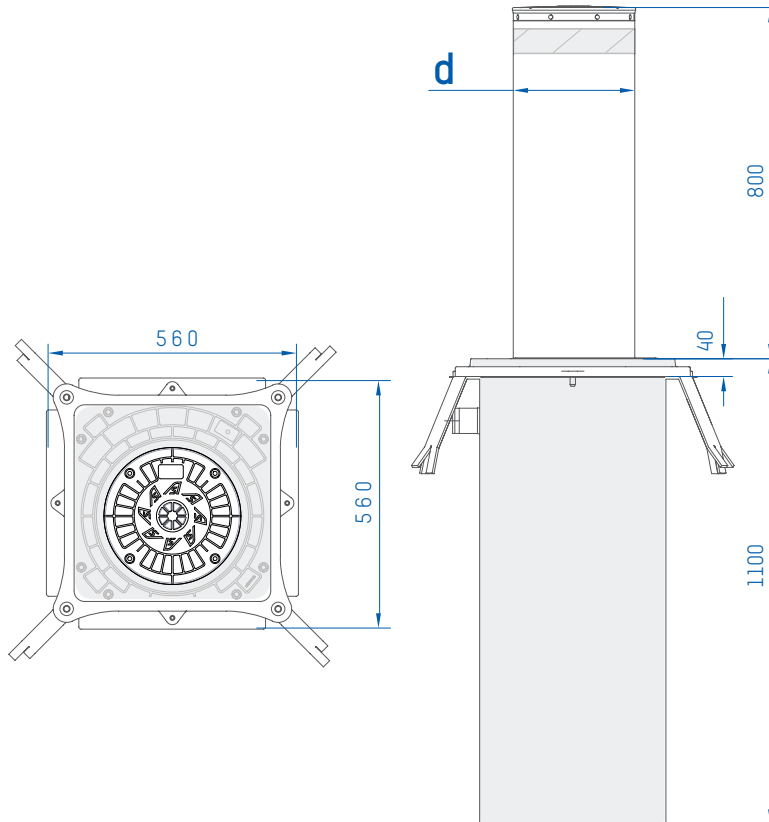

d	
Painted steel cylinder	Ø 271 mm
Stainless steel cylinder	Ø 273 mm



International & Headquarters

Automatic Systems SA

5 avenue Mercator
1300 Wavre - Belgique
Tel.: +32.(0)10.23.02.11

Email: sales.asgroup@automatic-systems.com

Belgium

Automatic Systems SA (Bruxelles & Wallonie)

5 avenue Mercator
1300 Wavre - Belgique
Tel.: +32.(0)10.23.02.11

Email: sales.be@automatic-systems.com

Automatic Systems Vlaanderen

Prins Boudewijnlaan 17 Unit 9A
2550 Kontich - België
Tel.: +32.(0)3.870.59.59

Email: sales.be@automatic-systems.com

France

Automatic Systems SAS - Persan

22, rue du 8 mai 1945
95340 Persan - France
Tel.: +33.(0)1.30.28.95.50

Email: sales.fr@automatic-systems.com

Automatic Systems SAS - Suresnes

3 Rue Salomon De Rothschild
92150 Suresnes
Tel.: +33.(0)1.41.11.40.20

Email: sales.fr@automatic-systems.com

Automatic Systems SAS - Lyon

Immeuble Le Québec
685, rue Juliette Récamier
69970 Chaponnay - France
Tel.: +33.(0)1.30.28.95.50

Email: sales.fr@automatic-systems.com

Spain

Automatic Systems Española SAU

Calle Bolivar, nº 24 Portal B 2º D
28045 Madrid - España
Tel.: +34.(0)91.659.07.66

Email: sales.ca@automatic-systems.com

Automatic Systems Española SAU

Calle Vallés, 52-54 - El Prat de Llobregat
08820 Barcelona - España
Tel.: +34.(0)93.478.77.55

Great Britain

Automatic Systems Equipment UK Ltd.

Units 18 - 19 Babbage House
Northampton Science Park
Kings Park Road
Northampton
NN3 6LG - UK
Tel.: +44 (0)16.04.65.42.10

Email: sales.uk@automatic-systems.com

Canada

Automatic Systems America Inc.

4005 Matte blvd., unit D
Brossard J4Y 2P4 - Canada
Tel.: +1 450 659 07 37

Email: sales.nam@automatic-systems.com

United States

Automatic Control Systems Inc.

45 Rockefeller Plaza, suite 2000
New York City, NY 10111 - USA
Tel.: +1 516 944 94 98

E-mail: sales.nam@automatic-systems.com