



The BL 44 is a very rapid rising barrier, short- and medium-range with reinforced oval section arm, for installation on public roads parking, traffic management, etc.

STANDARD RAL COLORS

Note: These RAL references are available for free.



CONFIGURATIONS

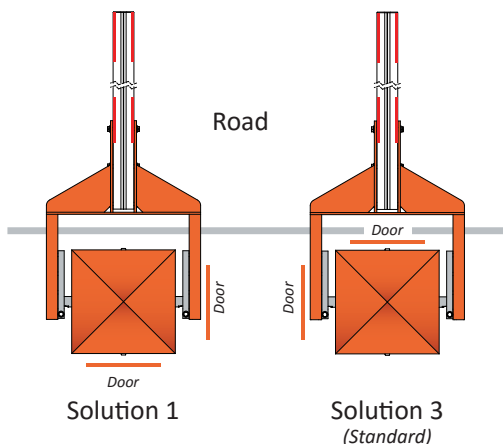

DESCRIPTION

1. Sheet metal body folded and welded, from 3 to 8 mm thick.
2. Lateral and frontal doors with peripheral sealing joint and lock, ensuring easy access to the mechanism. Two configurations are possible for their installation (see illustration).
3. Removable top cover, with lock and key.
4. Central oval reinforced section arm measuring 175 x 100 mm, in aluminium, white lacquered with red reflective strips.
5. Solid driving shaft for the arm, diameter 50 mm, mounted on 2 bearings lubricated for life.
6. Electromechanical assembly:
 - Reversible three-phase asynchronous gear motor, ensuring protection of the mechanism in the event of forced lifting of the arm due to fraudulent action.
 - Secondary transmission on gearwheel and sprocket wheel. Maintaining the arm in its two extreme positions (open and closed), as well as after a STOP command, is achieved by means of an electromagnetic brake.
 - Frequency inverter ensuring progressive accelerations and cushioned decelerations, for movement without vibration, direction inversion without jolts (reopening) and increased protection of the mechanism.
 - Electronic limitation of the electromechanical assembly torque allowing for the immediate stop of the arm during closing in the event of an obstacle.
 - Inductive limit switches.
 - Balancing of the arm by means of one or more compression springs, depending on the weight of the arm.
7. Lever for manual lifting of the arm (except for the automatic opening option).
8. Parameterisable electronic control board allowing for various control options and/or additional accessories.
9. Connecting terminal block on the control board:
 - Adjustable opening and closing speed
 - Arm position status (open or closed)
 - Technical fault information report
 - Human/Machine interface to change or adjust the electronic control board parameters
 - Status of the presence detectors
 - Socket for presence detector
 - ...

STANDARD TECHNICAL SPECIFICATIONS

Electrical power supply	Single-phase 230 VAC - 50/60 Hz + ground <i>(not to be connected to a floating network or to an industrial distribution network with a high impedance earth)</i>
Consumption	450 W
Motor	Three-phased asynchronous 250W
Reversible ring and pinion speed reducer, service factor 1.2	
Useful arm length (L)	2 to 4 m; in increments of 0.5 m
Operation not hampered by 120 km/h winds	
Ambient operating temperature	Between -20 and +50°C <i>(without optional heating)</i>
Tolerated relative humidity	95% without condensation
Minimum opening/closing time	2 s <i>(adjustable through the control board)</i>
Net weight <i>(without arm)</i>	250 kg
MCBF <i>(Mean Cycle Between Failure)</i>	in compliance with recommended maintenance: 5,000,000 cycles
IP	44
CE	EC compliant

SURFACE TREATMENTS

- Zinc-coated internal mechanical parts
- Complete body (housing, base plate, cover and doors): zinc dusting + epoxy structured
Total thickness of the surface treatment exceeds 160 µm

WORKS TO BE SUPPLIED BY THE CUSTOMER

- Adapted ground fastening
- Power supply
- Wiring towards eventual external peripherals
Note: comply with the installation plan

STANDARD DIMENSIONS (mm)

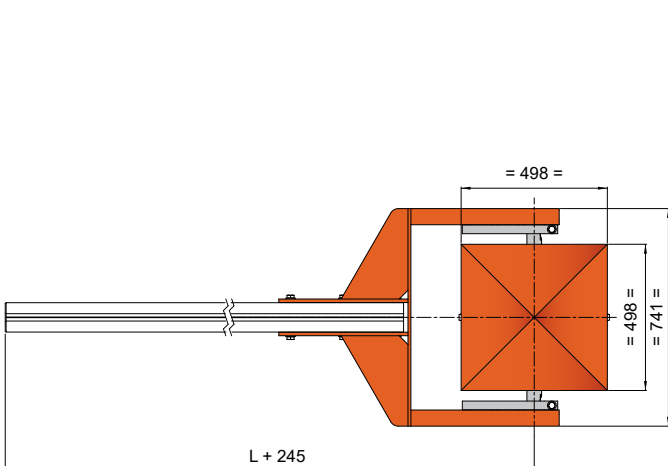

OPTIONS

1. Locking the arm in opened and/or closed position.
The reaction in case of power cut (locked or not) must be specified when ordering
2. Double limit switches for information on the arm status in the event of power failure.
3. Tip support: fixed height tip, adjustable tip, electromagnetic tip, antivandalism tip, antivandalism + electromagnetic tip, folding tip and electrically lockable tip.
4. Rotating base with breaker pin in case of impact and report of housing position by dry contact.
5. Anti-vandalism belt, protection of the doors and hood.
6. Bolt cover - to protect arm from vandalism.
7. Hood and door intrusion information *(by dry contact)*.
8. Push-button box.
9. Fireman emergency opening - antivandalism.
10. Programmable clock *(weekly or yearly)*.
11. Lockable switch on housing.
12. Radio transmitter/receiver.
13. Detection loop.
14. Presence detector for inductive loops.
15. Photoelectric cell for opening, closing or automatically stopping the barrier arm.
16. Cell support post.
17. Fixating of the cell.
18. Ultrasonic detector in housing.
19. Electronic board for input/output CAN.
20. Totalling counter with reset button.
21. LEDs on arm.
22. Traffic lights (LED) - alone or fixed on barrier.
23. Support post for traffic lights.
24. AS1049 card for third-party traffic signs.
25. Acoustic alarm 100 dB (± 5) - fixed inside.
26. Aluminium traffic sign ($\varnothing 300$ mm).
27. LED flashing light on cover for arm movement signalisation.
28. Anti vandalism LEDs on hood.
29. Non standard RAL color.
30. Treatment for aggressive saline environment.
(Recommended when the barrier is installed within 10 km of the coast and may be subject to salt attack): sandblasting + Alu Zinc plating 80µm outside (40µm inside) + polyzinc 80µm + 80µm powder paint).
31. Raised base.
32. 120 VAC - 60 Hz power supply.
33. Thermostatic 250 or 500 W heating for operation to -25 or -45°C.

Note: for restrictions on the options, consult the rate table

