

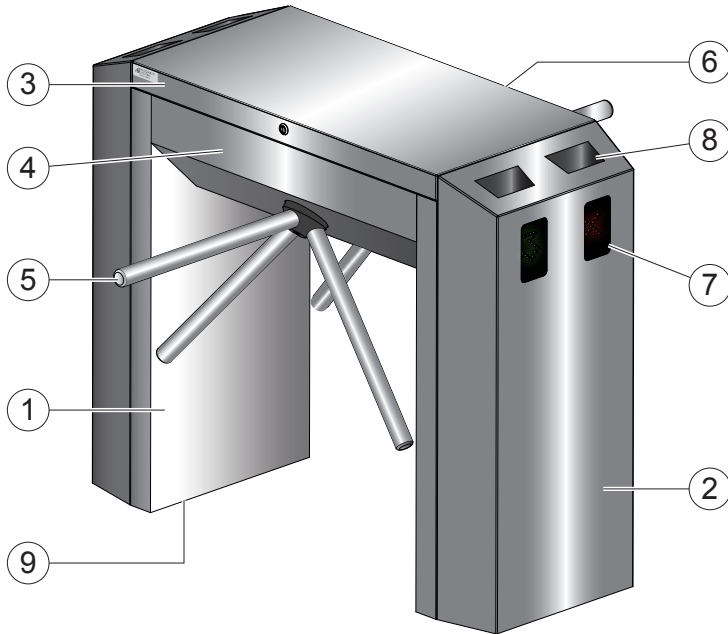

Description

1. AISI 316L stainless steel sheet frame.
2. Front and rear sections made of AISI 316L stainless steel locked from inside. These sections can not be opened before upper cover removal. They are designed to incorporate user control equipment such as card reader, coin acceptor, proximity reader, etc.
3. Upper cover in AISI 316L stainless steel with lock, to ease access to the turnstile mechanism and to open the columns.
4. Two tripod turnstile mechanisms with solid steel arms and capstan on ball bearings, protected by a black PVC hub cover. Electromagnetically operating locking bolts mounted on self lubricating bearings to lock arms. Hydraulic adjustable pressure movement shock absorber ensuring silent smooth operation and progressive slowing down of the arm rotation even when used with force. Reversed rotation prevented by the anti pass back device
5. AISI 304 stainless steel arms with locking device preventing the arm from being removed without appropriate tools.
6. Two programmable electronic control logics TR6.



Each gate is designed to accommodate:

7. orientation pictograms (optional).
8. contactless card readers integration under a plexi screen (optional).
9. Floor fixing by means of expansible plugs.

Operation

The tripod turnstile mechanism can operate in 5 different modes.

1. Access permanently free
2. Access permanently mechanically locked
3. Access mechanically locked with automatic unlocking device to give free passage in case of power failure. (Free-rotation)
4. Electrically controlled access
5. Access electrically controlled with automatic unlocking device to give free passage in case of power failure. (Free-rotation).

The mode of operation is defined by specifying the code number above for all directions, which corresponds to the operation selected (see Conventions).

The double turnstile **TR 492** was designed to ensure the pedestrian access control aesthetically thanks to the incorporation of two tripods mechanisms in only one housing. Furthermore, it reduces overall dimensions and infrastructure works needed for the implementation thereof: time of installation, electrical wiring of power supply and connection, etc.

The **TR 492** operates autonomously and can incorporate access control devices such as: card readers, coin/token acceptors, ticketing systems, etc ...

Their mechanical design is strong and reliable. They exist in different configurations to suit all architectural requirements in terms of pedestrian access control.

The **TR 492** double turnstile can be installed indoors or outdoors under a canopy, alone or in combination with one or more TR 490 or TR 491. A combination with a PPV323 gate is also possible to allow persons of reduced mobility to pass.

Conventions

Direction A/D = housing at right hand side of the walkway
 Direction B/C = housing at left hand side of the walkway

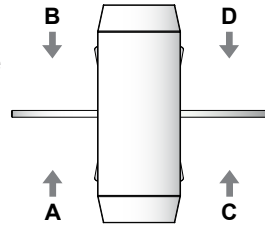

Examples:

1. Turnstile electrically controlled in direction A & C and free in direction B & D is a TR 492 A4/B1/C4/D1 type turnstile.
2. Turnstile electrically controlled in direction A with automatic unlocking device, always blocked in direction B & C, and electrically controlled in direction D is a TR 492 A5/B2/C2/D4 type turnstile.

Standard technical specifications

- Power supply: 100 - 230V single phase 50/60 Hz.
- Control circuit: 24V DC.
- Electromagnet: duty cycle 100%.
- Nominal consumption: max. 120 W.
- Shock absorber: hydraulic.
- Ambient operating temperature: -10° à + 50° C.
- Flow: 20 passages/minute.
- Net weight : 148 Kg.
- MCBF (*Mean Cycles Between Failures*), when respecting recommended maintenance: 5,000,000.
- This equipement is IP43.
- EC compliant.
- 5 years warranty* applicable after sales agreement.

*As per our general terms & conditions of sale and preventive maintenance programs.

Anti corrosion treatment

Internal mechanical parts are treated by zinc coating and passivation.

Options

- Kit for readers integration + orientation pictograms:
 - 2 orientation pictograms (red cross / green arrow).^(a)
 - 2 cuts out in the front or rear end sections to integrate the customer's control equipments, according to dimensions and positioning to be communicated (maximum width: 190 mm, maximum depth: 200 mm).
- Heating for operation until -20 °C.
- Token or coin acceptor integrated in foot with door and receptacle.^(a)
- Token.
- Closing side panel.
- Empty housing.
- Tropicalisation kit (IP44).
- Additional power supply 120 V - 60 Hz.

^(a) *Incompatible options.*

Work to be provided by the customer

- Power supply.
- Connecting electrical wiring to the control units.
- Possible masonry and fixing work (see installation drawing).

Standard dimensions (mm)

