

SLIM944

Technical datasheet

NAM-SLIM 944-FT-EN-V

//SlimLane



AUTOMATIC SYSTEMS

Access controlled...

Future secured

DESCRIPTION

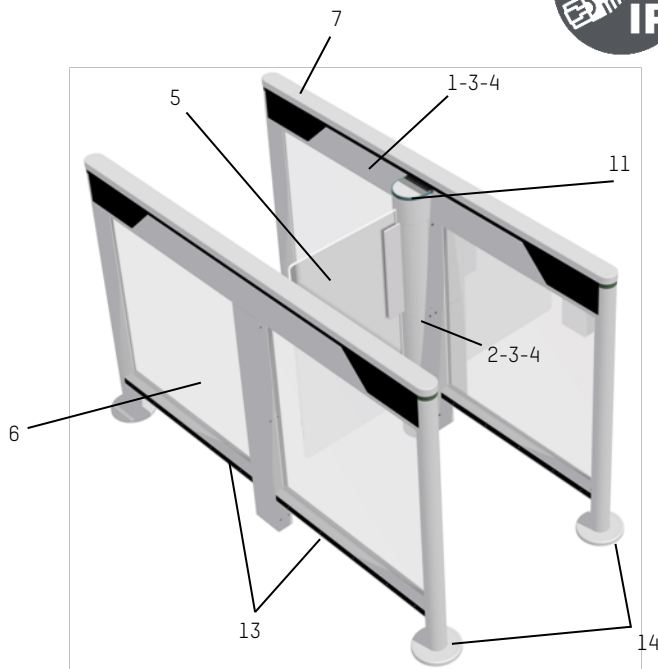

The SlimLane 944 single swing door security entrance lane offers a high bidirectional throughput and uncompromising security.

With its transparent, elegant design and minimal footprint, the SlimLane 944 is designed to integrate perfectly into any architectural style.

Equipped with high processing capacity and an exclusive detection system, the SlimLane 944 guarantees accurate user tracking and prevents any unauthorized use.

The SlimLane 944 is a modular product that can be installed as a single lane or a multi-lane array. It can be combined with the SlimLane 940 standard lane and the SlimLane 950 wide lane model.

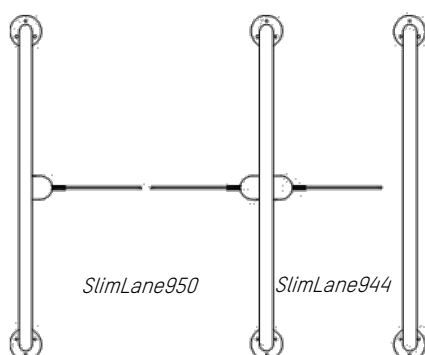

- Handrail frame:** steel beam with RoHS anti-corrosion zinc plating treatment and stainless steel posts. The handrail includes photoelectric cells for user detection and the logic control board.
- Self-supporting kinematic steel frame** with RoHS anti-corrosion zinc plating treatment. The frame contains the electromechanical drive assembly for the swinging obstacle and the electronic control boards.
- Brushed #4 AISI 304L stainless steel housing.**
- Brushed #4 AISI 304L stainless steel panels** fastened to the frame for access to the internal components.
- Clear, 3/8 in (10 mm) thick tempered monolithic glass obstacles**, swinging in the direction of user passage.
- Clear, 1/4 in (6 mm) thick tempered glass side panels.**
- Brushed #4 AISI 304L stainless steel top cover.**
- Electromechanical drive unit consisting of:**
 - A DC permanent magnet motor with an epicyclic gearbox.
 - A controller which provides progressive accelerations and decelerations of the obstacles, for smooth movement and enhanced user safety.
 - A geared electromagnetic brake for locking of the obstacles in the event of forced entry attempts.
 - A sensor to monitor the obstacles position.
 - EGRESS standard operating mode: obstacles open in the direction of egress with a simple push.
 - Battery backup for automatic opening in case of power failure in egress direction.
- AS1190 logic control board**, equipped with ARM 9 technology and Linux operating system, ensuring advanced traffic management. An embedded web server, accessible through a web browser, offering an interface for the configuration of functional gate parameters, as well as a complete diagnostic and maintenance tool.
- Transfer of information through an Ethernet interface**, USB and dry contacts: passage authorization, passage information, reader locking, fraud, equipment failure ...
- Orientation and function pictograms indicating gate and passage status to the user.**
- Proprietary DIRAS detection system**, consisting of a high-density matrix of infrared transmitter/receiver photocell beams. It follows users' progression through the gate, as well as ensuring their safety during opening/closing of the obstacles.
- Enhanced electronic protection and luggage detection cells** (A and B directions).
- Finishing plate for posts.**

STANDARD TECHNICAL CHARACTERISTICS

Power requirement	15A @ 24 VDC 6A @ 120VAC (optional)
Consumption per lane	40 W (at rest) 120 W (nominal)
Motor	24 VDC – 93 W
Passageway (W)	23 in (584 mm)
Min opening and closing times	1.0 to 1.2 s (Depending on the access control system reactivity and the speed of users)
Ambient operating T°	32 to 122°F (0 to +50°C)
Ambient relative humidity in operation	< 95%, no condensation
Sound level	55 dB
Weight	Kinematic unit: 141 lbs (64 kg) Handrail: 88 lbs (40 kg)
IP	40
Certification	As per UL 2593, File E210350

PRECAUTIONS FOR USE

- For security reasons, children (users smaller than 39" tall) must be supervised by an adult at all times when in the vicinity of the unit and during passage through the lane.
- A child must absolutely precede the accompanying adult.
- If habitual use by children is anticipated, please ensure that the units include the glass side panels + the electronic sensor enhancement kit.

OPTIONS

- 120VAC Power supply
- SECURI-SAFE operating mode: electromechanical locking of the obstacles in case of forced entry attempt in any passage direction
- High glass options: 47" [1194mm], 59" [1499mm], 67" [1702mm] and 72" [1829mm] available
- Standard reader integration within housing
- Standard support bracket for surface mounted reader integration
- Barcode reader integration*
- Custom top cover
- Customized logo on obstacle
- Raised base*
- Ramp*
- Monitoring panel (Smart'n Slim / manual CP)
- Connectivity kit for Ethernet connection of one or more lanes to the network
- Short cabinet- 50 ³/₁₆" long [1275mm]
- Flangeless
- Extended posts. (EP / EPR)*
- Lighted side glass panels
- Swing arm obstacles*
- Optical version*

For restrictions on options please speak to your sales representative.

* See respective datasheet for more information

WORK TO BE PROVIDED BY OTHERS (NOT SUPPLIED)

- Performing the electrical interconnection and connections to the power grid.
- Performing the connections to the access control systems.
- Anchoring the equipment with the appropriate hardware for your floor type.

Refer to the installation drawing

