

# ADA GATE

Technical datasheet

NAM-ADAGATE-FT-EN-E

**A**UTOMATIC  
SYSTEMS

Access controlled...  
Future secured



View from entry side  
(Unsecured side)

View from exit side  
(Secured side)

## DESCRIPTION

1. **Adjustable self-closing hinges**
2. **Grey RAL7038 powder coated steel frame** to match with the TRS standard color
3. **Electrical strike** to control access to the controlled area.
4. **Panic bar exit device** allows the gate to be egress compliant.
5. **Exterior key lock handle** to override.
6. **Security panel covering the Panic Bar area.**
7. **Gate opening is 180 degree.**

The full height manual ADA swing gate complements TRS full height turnstiles. This swing gate offers a wide entryway, ideal for ADA access, freight or emergency egress.

- Safe, simple, and effective equipment allowing for prolonged use, even in the harshest conditions
- Long term investment based on exceptional durability

Applications: Industrial sites, administrative buildings, schools, hospitals, stadiums and sports complexes, amusement parks, ports, airports and military bases.

The ADA gate can be ordered in right or left orientation and the standard color is RAL7038 to match with the TRS. Custom colors are available as an option.

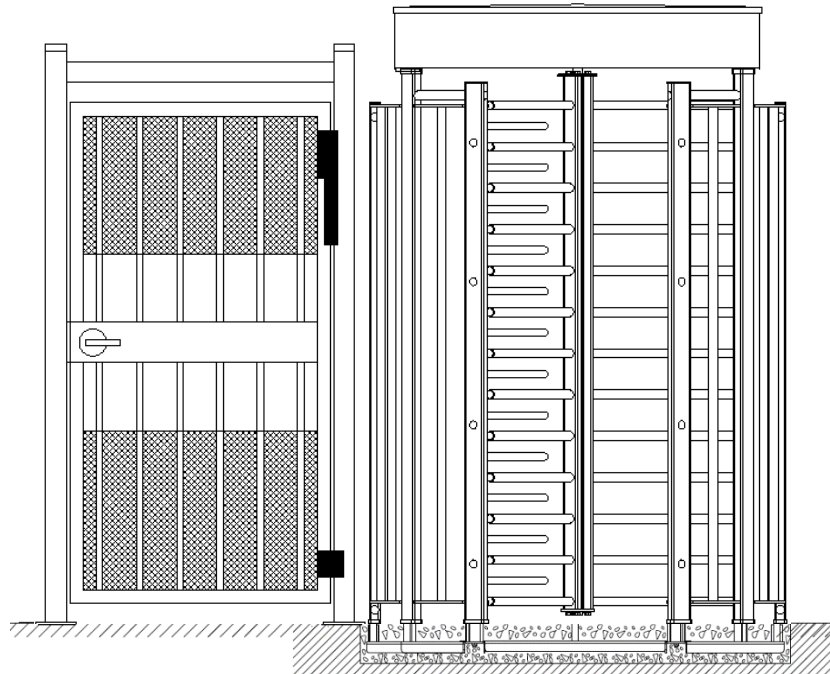

[www.automatic-systems.us](http://www.automatic-systems.us)

[www.automatic-systems.ca](http://www.automatic-systems.ca)

## STANDARD TECHNICAL CHARACTERISTICS

## OPTIONS

Power requirement	12/24 VDC
-------------------	-----------

1. Reader integration
2. Customized color
3. Customizable passage width: 38" [965mm] to 48" [1220mm]

### SURFACE TREATMENT

- Sand blasted, primer, powder coated

For restrictions on options please speak to your sales representative.

### WORK TO BE PROVIDED BY OTHERS (NOT SUPPLIED)

- Performing the connections to the access control systems.
- Anchoring the equipment with the appropriate hardware for your floor type.

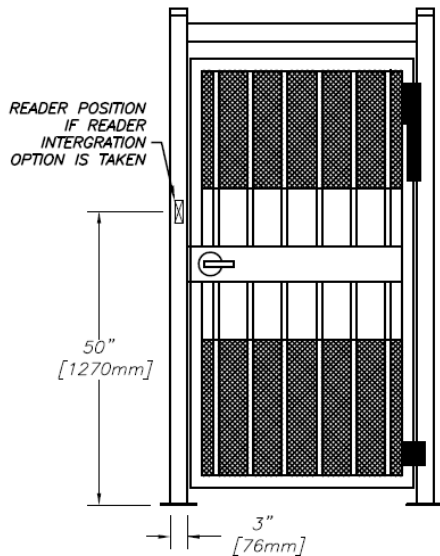
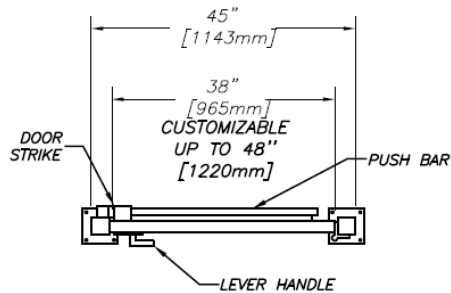

View from entry side  
(Unsecured side)

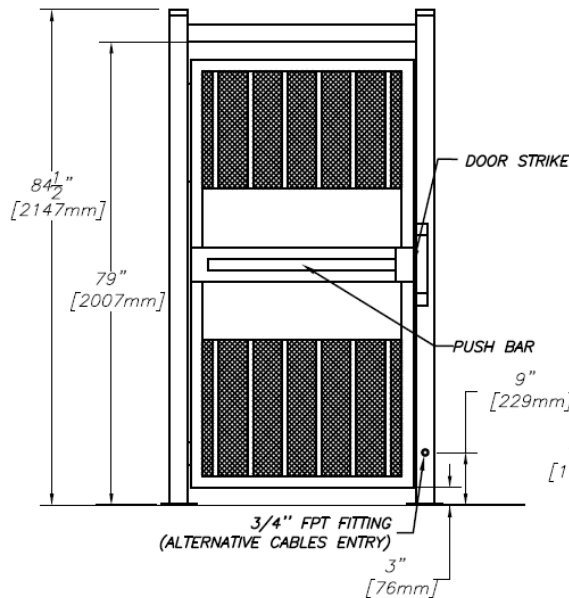

View from exit side  
(Secured side)

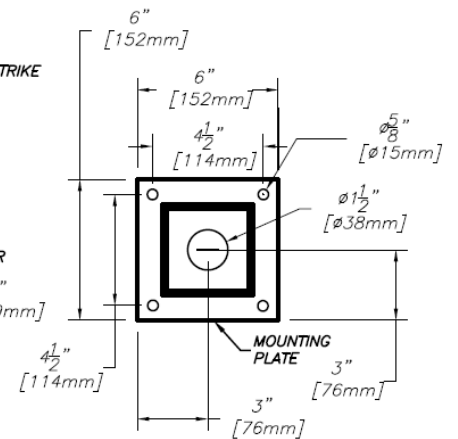

Mounting plate details